

Intertek

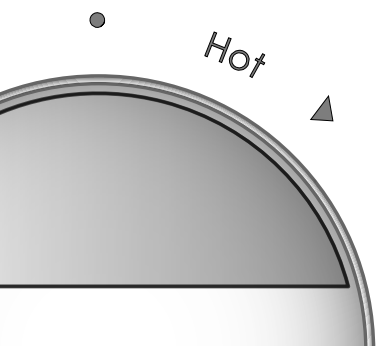
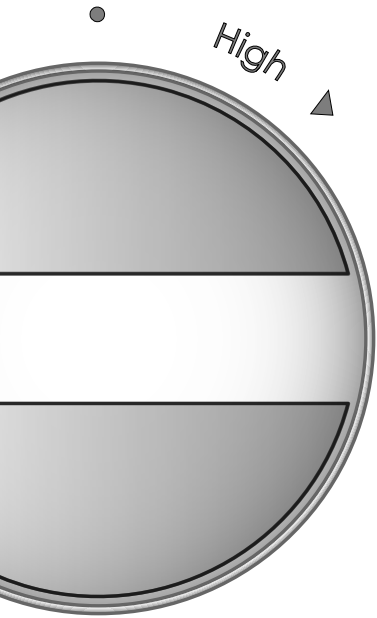

i therm

Electric Shower

Installation and Instruction Manual

Installer - please read all instructions carefully before installation and leave this manual with the end user for future reference



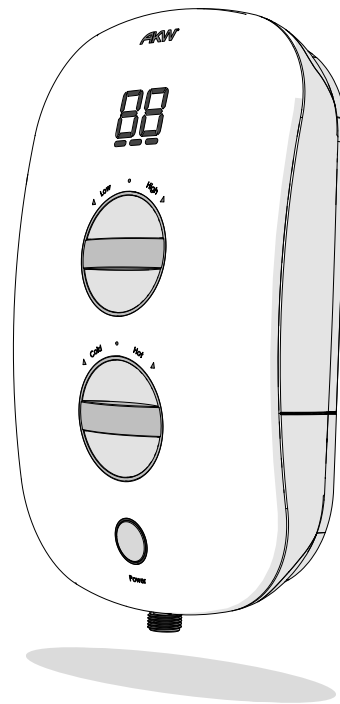

8
Water Inlet
Entry Points

8
Electrical Cable
Entry Points

The iTherm Electric Shower has been designed to allow for easy operation. The large ergonomic control knobs and LED interface clearly indicate the temperature and flow rates. The iTherm Electric Shower also allows for easy flexible installation with its inlet layout.

Thermostatic Control - The outlet water temperature is thermostatically maintained

Automatic Shut Down - The shower automatically shuts down after 30 minutes operation (this can be bypassed 30 seconds prior to shut down)

Phased Shut Down - Flushes the shower with cold water to avoid the possibility of scalding if the shower is restarted within a short period of time

Flexible Installation - 8 water and cable entry points

Dual power blocks for left or right wiring

Retro-fit footprint

5 year warranty

8.5kW or 9.5kW options available

Wired and wireless connectivity to all AKW DigiPump shower waste pumps

Introduction	2-3
Product Features	2
Contents	3
User	4-10
Safety Information	4
Operating Instructions	5
Cold Water Setting	6
Sound Setting	7
Maintenance and Cleaning	8
Troubleshooting	9
Warranty	10
Installer	11-17
Main Components	11
Specifications	12
Installation Requirements	13
Disassembly	14
Fitting to wall	15
Reassembly - Bottom Cover	16
Reassembly - Front Cover	17

Plumbing	18-21
Water Requirements	18
Plumbing Connections	19
Plumbing Entry Points	20
Check List	21

Electrical	22-26
Electrical Requirements	22-23
Electrical Entry Points	24
Connecting Waste Pump	25-26

Commissioning	27-33
Temperature & Mode Settings	27
Cold Water Flushing	28
Functional Checks	29
Troubleshooting for Engineers	30-31
Cleaning the Filter	32
Commissioning Tests	33

Failure to install this AKW product in accordance with supplied instructions or the making of unauthorised modifications will invalidate any warranty and may affect product safety.

Please ensure the warranty card details are filled in and returned in the envelope provided. Alternatively visit our website and register online. www.akw-ltd.co.uk/warranty

These instructions are provided to advise the minimum standards of installation and recommend the best practice for the installation. Due to the wide variability of possible installation conditions, AKW cannot provide every solution for the installation. AKW does not accept any liability in connection with this information or its use. This information is provided on the condition that the person receiving it shall make their own tests to determine the suitability for their particular purpose. None of the foregoing affects your statutory rights.

This appliance can be used by any persons, including children from 8 years and above.

Children should be supervised and have had the correct instructions on how to operate the appliance correctly. Make sure that they do not play with the appliance and use it correctly.

Ensure that the temperature is not set to maximum before showering. Sunburn or skin conditions can increase your sensitivity to hot water. Make sure that you set the shower to a cooler temperature.

Do not operate shower if you suspect the water in the heater tank is frozen or the appliance has been susceptible to freezing conditions.

Do not operate the shower if the spray handset or hose is damaged, twisted or blocked in anyway.

Do not restrict flow out of the shower by blocking or obstructing the hose or spray handset.

Do not use other shower hoses and handsets with this shower. Using other handsets or hoses will make this shower a non-care approved shower. Only use AKW approved products with this shower as this may affect the warranty.

1. Temperature Indicator

This digital display is an indication of the water temperature inside the unit, not the outlet temperature. When the Temperature Control is adjusted (4), the target temperature will display and flash. It will stop flashing once the desired temperature has reached its target.

The display may flash again when it goes outside the desired target temperature (+/-2°C). Any slight up or down fluctuations on the display during use are normal.

2. Flow Range Indicator

This digital display is an indication of the current flow rate setting.

Low 
 Medium 
 High 

3. Flow Control

Adjustable flow control

4. Temperature Control

Adjustable temperature control

5. Power Button

Push button to power on/off the shower

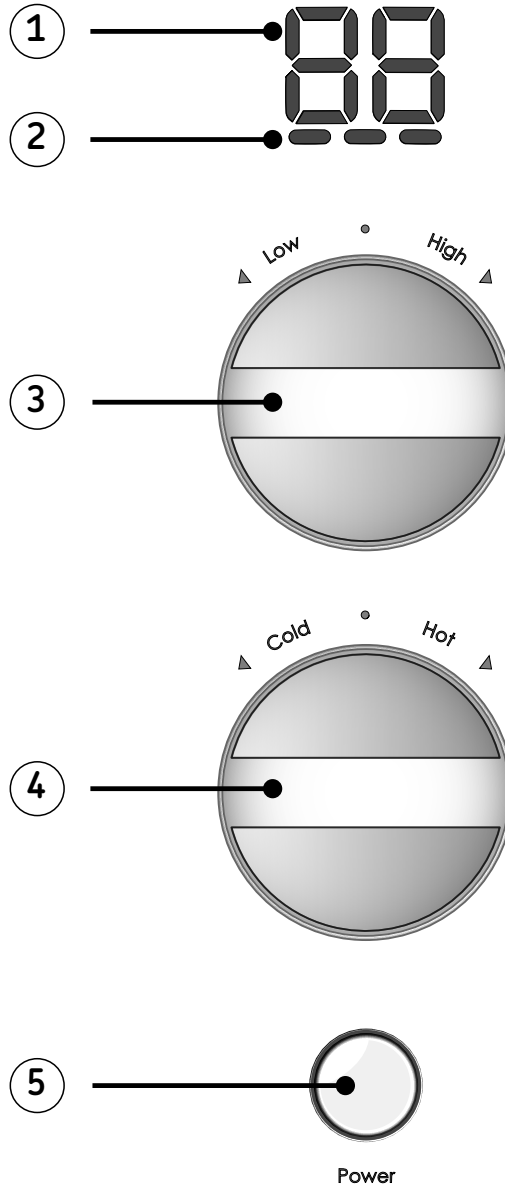

Starting the Shower

Switch on the mains power at the isolating switch. When the power is first turned on, the outer light ring around the power button will be lit and the shower is in standby mode.

To switch on, press and release the power button, the temperature and flow rate will be indicated on the display. To switch off, press and release the power button to stop water flowing. Your iTherm shower will enter into phased shut-down mode to allow for the hot water to flow for a short period of time while the heater cools down before automatically turning off.

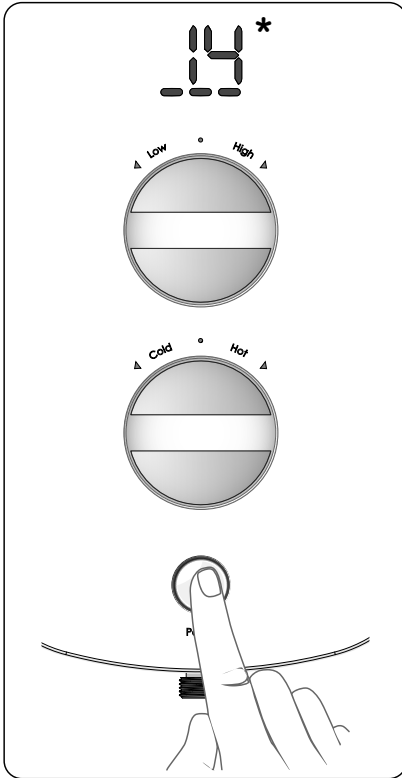

Step 1

Turn on power at pull cord/switch.

Press the power button

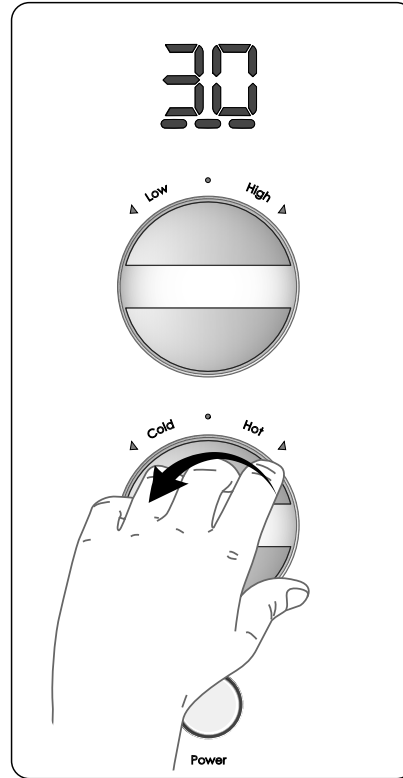

Step 2

Turn the Temperature control knob anti-clockwise until the temperature display is shown like the illustration

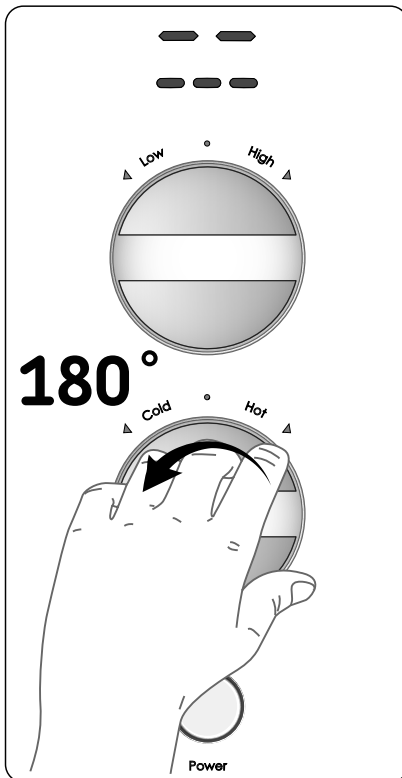

Step 3

Turn the Temperature control knob 180° anti-clockwise and the shower will enter cold flow (no heating)

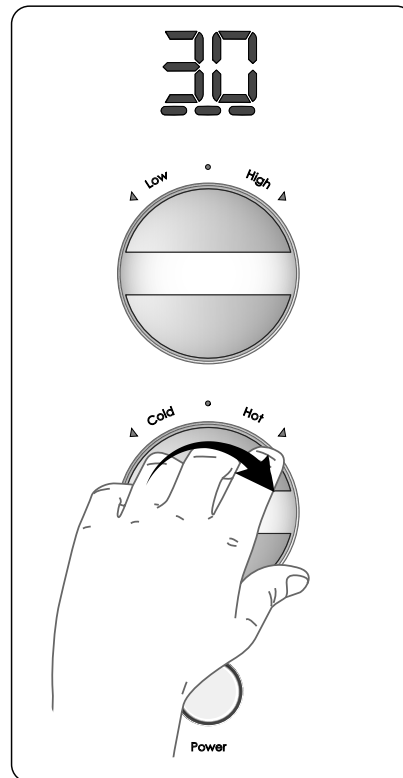

Step 4

To adjust the shower back to 30°C, turn the Temperature Control knob by two clicks (NOT 180°).

*Inlet water temperature will vary dependent on season and location

The iTherm Electric Shower has audible tones enabled in its factory settings. This can be enabled/disabled for your preference. Please contact a qualified local installer and refer them to Page 27 to change it to your preference.

When enabled, audible tones occur in the following state:

- Single beep when switched on
- 2 beeps when Temp/Flow are at the end of their adjustment range
- Multiple (approx. 8) when in phased shut-down
- Multiple beeps for 30 seconds after the shower has been running for 30 minutes

Always isolate power supply before cleaning. Do not operate if the shower unit is frozen. Clean and descale the shower head regularly.

The shower unit and surrounding areas should be cleaned periodically to remove any accumulation of dirt or other waste materials, using domestic bathroom and kitchen cleaning materials with a soft cloth.

Do not use abrasive pads or cloths. Do not use strong or concentrated acidic, alkaline or other cleaning materials as these may damage or discolour the product.

After cleaning always wash down with water then wipe thoroughly with a damp soft cloth to remove any cleaning material residue.

DO NOT position the handset to spray water directly on to the appliance.

Children should be supervised at all times if they use the shower appliance or attempt to clean it.

Read and understand the user guide before commencing troubleshooting

Symptom	Possible Cause	Remedy
No Water Flow	Water isolating valve in off position	Turn on water supply
	Filter blocked	Turn off water and electrical supply, remove filter and clean see page 32.
	Thermostat tripped	Turn handset to wall. Perform cold flush. see page 28.
No Lights on	No mains power supply	Turn on the isolating power supply.
Abnormal temperatures	Faulty thermistor	Call your local installer
Reduced water flow	Reduced pressure Blocked hose or handset	Check and clean the handset. Press the flow increase button and/or press the temperature decrease button.
	Water pressure is below minimum requirement. This may be caused by other appliances on the same pipework drawing water	Check other draws offs. Check running pressure (minimum of 0.5bar) (1bar Recommended)
Wireless Pump not responding	Faulty wireless pump link (if installed)	Not Paired No Power to the Pump RF interference
Fault LED's Display (See Page 30 for reference)	Low Flow/Low Pressure Inlet thermistor Fault Outlet thermistor Fault Uncontrolled over temperature	Call your local installer who then should call the AKW technical helpdesk. Refer to back page.

If the shower does not work as expected, switch off at the pull-cord or isolating switch, wait 30 minutes for the shower to reset then switch back on again.

AKW guarantee your shower against any defects in manufacturing or materials for 5 years from the date of installation. Please ensure you have completed the warranty card enclosed and return to AKW within 30 days to activate this warranty offer. Alternatively visit www.akw-ltd.co.uk/warranty and complete the online registration form. Within this period AKW will decide to repair or replace as we may choose. Failure to activate warranty in set period will mean potential charges should a visit to site be required by an AKW Maintenance Engineer. Any action taken under this warranty does not extend the stated 5-year expiry date. Contact information can be located on the back page. This guarantee is in addition to your statutory and other legal rights. None of the foregoing affects your statutory rights.

Not covered by this warranty:

- Damage or defects that result from inappropriate use or accidental damage, incorrect installation, or lack of maintenance including but not limited to the build up of limescale, system debris or pipe scaling, grime, dirt or water-borne debris.
- Damage resulting from inappropriate cleaning or water ingress.
- Damage resulting from water freezing.
- Damage resulting from PRD activation from either a blocked hose or a blocked shower handset.
- If the product is taken apart.
- Damage or defects that result from repairs or modifications undertaken by persons who are not installers or AKW service engineers.
- Malfunction resulting from incorrect use.
- Failure to install in accordance with the installation instructions or performance issues arising from incorrect installation.
- Claim for a defect identified at the point of delivery, once the product is fitted (unless authorisation from AKW Medi-Care Limited has been granted).
- In-situ impact damage.
- Water, electrical, pressure or isolation issues.
- Wear and tear from routine maintenance, cleaning, adjustments, corrosion or erosion.

If you need any advice or if you have any questions, please contact AKW Technical Enquiries with your model number and date of purchase.

For technical faults always refer to the trouble shooting guide before contacting your local installer for assistance. If your installer should need further assistance then contact AKW Technical Enquiries (see back page for contact details).

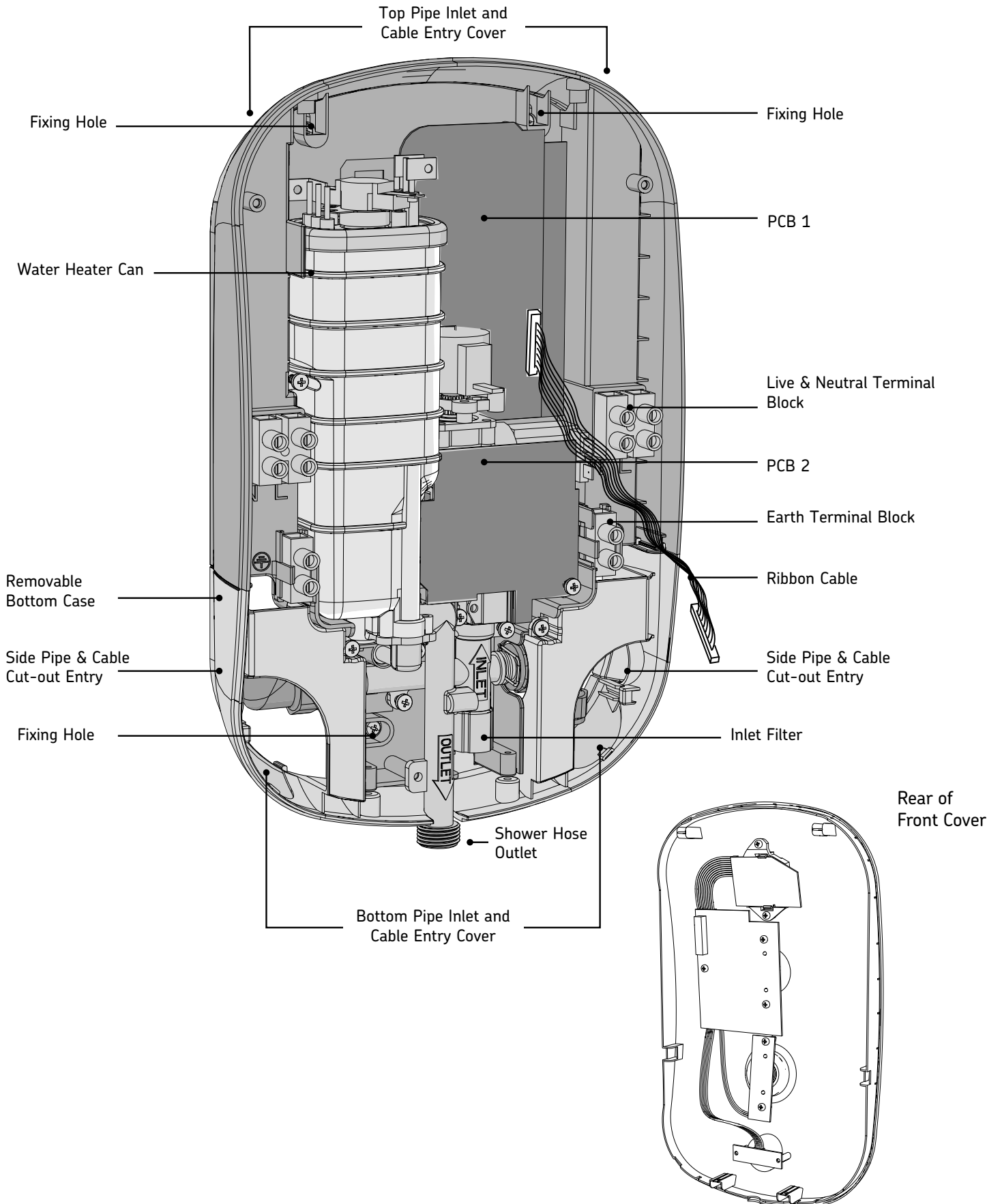

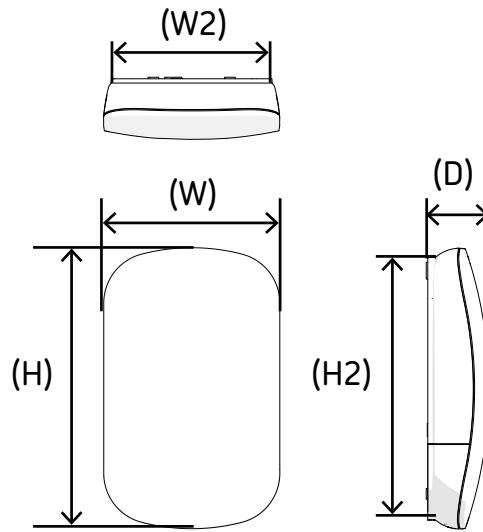

PLUMBING SUPPLY	Supply Source	Mains pressure cold water only
	Minimum Dynamic Pressure	50kPa (0.5 Bar)
	Maximum Static Pressure	1000 kPa (10 Bar)
	Optimal Minimum Dynamic Pressure*	100 kPa (1 Bar) (Recommended to ensure high performance)
	Maximum Inlet Temperature	28°C
	Minimum Inlet Temperature	3°C
	Inlet Connection	15mm pipe
Outlet Connection	1/2" BSP Male Thread Fitting	
ELECTRICITY SUPPLY	Nominal Rating at 240 V	9.5kW & 8.5kW
	Supply Fuse / Circuit Breaker Residual Current Device (RCD)	(9.5kW 40/45A) & (8.5kW 35/40A) 30 mA (must be fitted)
	Supply Cable	Refer to current wiring regulations and BS 7671 to determine minimum cable size. No larger than 10mm ²
	Isolation Switch (e.g. Pull Cord)	45 Amp Double pole with 3mm contact separation.
PHYSICAL	Height	(H) 380 mm
	Width	(W) 230 mm
	Depth	(D) 85 mm
	Footprint Height	(H2) 345 mm
	Footprint Width	(W2) 210 mm
	Water Ingress Rating	IPX4
	Water and Cable Entry Points	Top, bottom, side or back.
	Shower Drain Pump Connections	Suitable for M Series (Flow Sensor) or AKW A4 (Flow Switch)

Installation Requirements and positioning

The shower must only be connected to the mains cold water supply.

The shower must not be positioned where it will be subjected to freezing conditions.
Position the shower unit vertically.

The shower must always be mounted on a finished flat, waterproof surface.
Never tile up to the shower unit.

Do not seal the shower to the wall with silicone or other sealant.

The flat surface must cover the full width and height of the back plate, otherwise difficulty may arise when fitting the cover and subsequent operation of the unit may be impaired.

The water outlet pipe acts as a vent and must never be blocked, restricted or connected to any parts other than those AKW specifically state for use with the AKW SmartCare Plus shower.

Ensure the shower unit is positioned over a bath, shower tray or wet floor.

The shower head must be directed away from the shower unit, during normal use the shower head must not spray directly on to the shower unit.

Before you start work:

Take care when you unpack the product and make sure that you do not inadvertently discard any small parts. Check the contents supplied against the contents page. If any parts are missing or damaged, contact the AKW Technical Enquiries team.

Check there are no pipes or electrical cables inside the wall before drilling.

Check that finished walls are sound and free from cracks or loose tiles or grout. Make sure that all surfaces are clean, dry and free from loose debris or dust.

This product is not suitable for mounting into steam rooms or steam cubicles.

Note; If it is intended to operate the shower in areas of hard water (above 200 ppm temporary hardness), a scale inhibitor may have to be fitted.



Ensure that the electrical supply is switched off at the mains.
Ensure that the water supply is turned off.

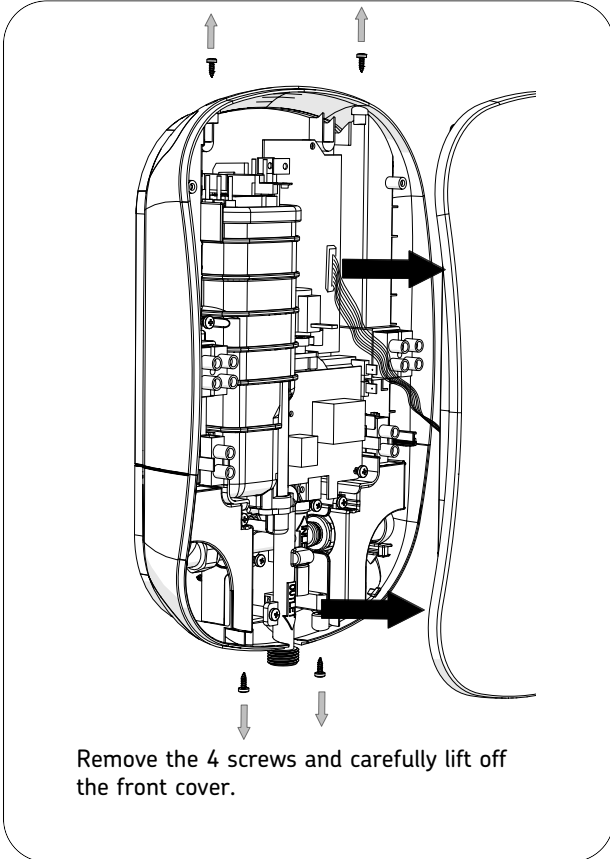

Remove the 4 screws and carefully lift off the front cover.

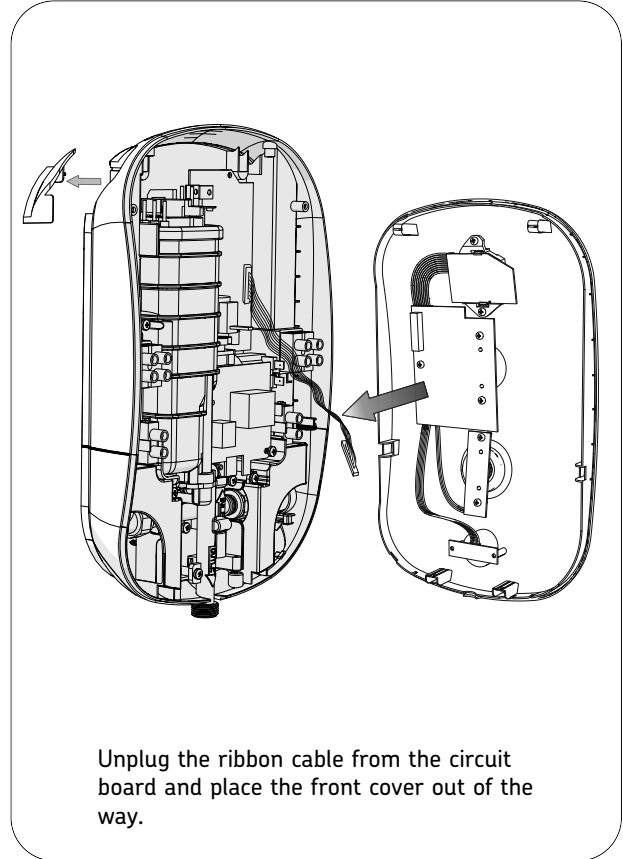

Unplug the ribbon cable from the circuit board and place the front cover out of the way.

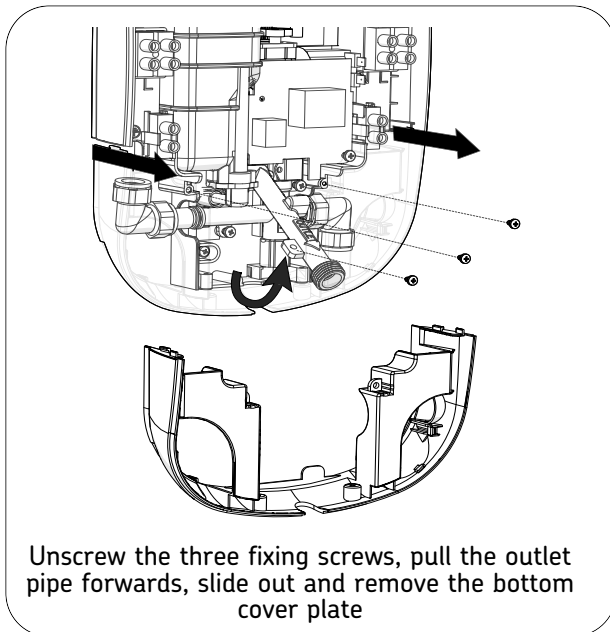

Unscrew the three fixing screws, pull the outlet pipe forwards, slide out and remove the bottom cover plate

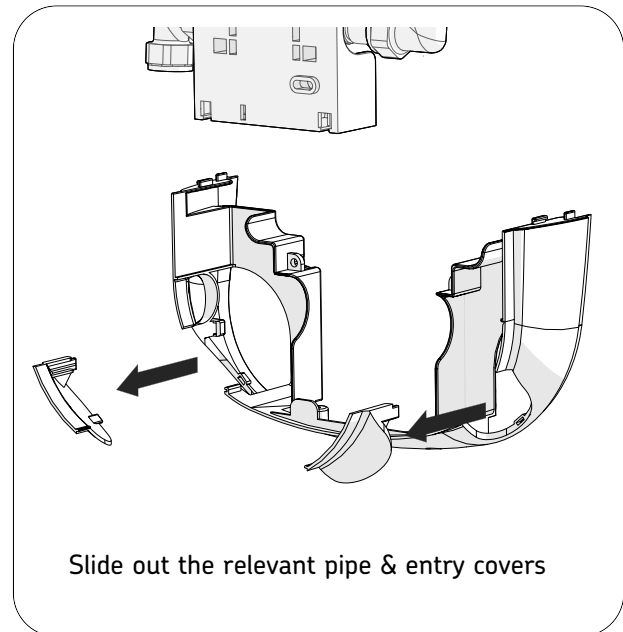

Slide out the relevant pipe & entry covers

Note the unit can be temporarily hung using the top screws fixings whilst the cable and pipe work entries can be connected.



It is essential to remove any debris and/or brick dust that could otherwise damage the unit.

Do not make any alternative or additional fixing points, as this will invalidate the warranty. Check for hidden cables and water pipes.

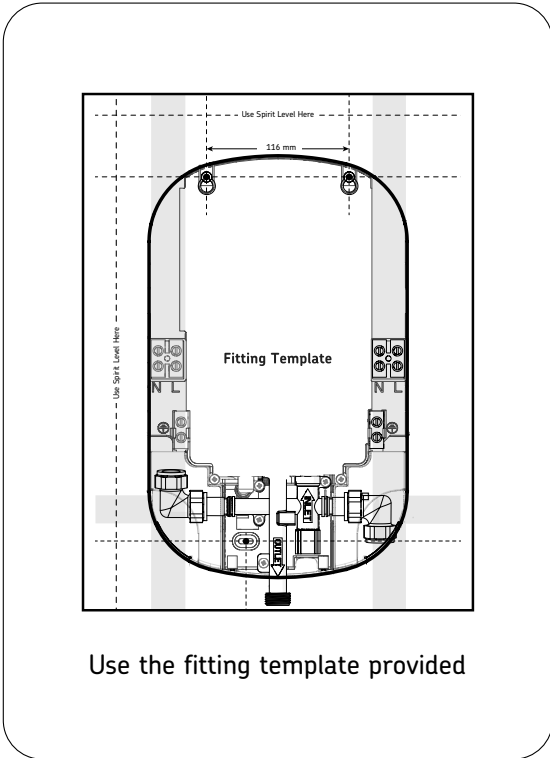

Use the fitting template provided

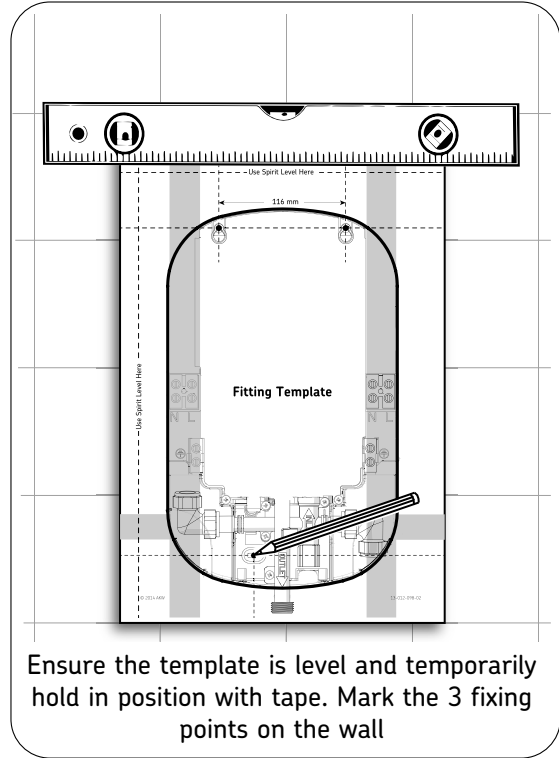

Ensure the template is level and temporarily hold in position with tape. Mark the 3 fixing points on the wall

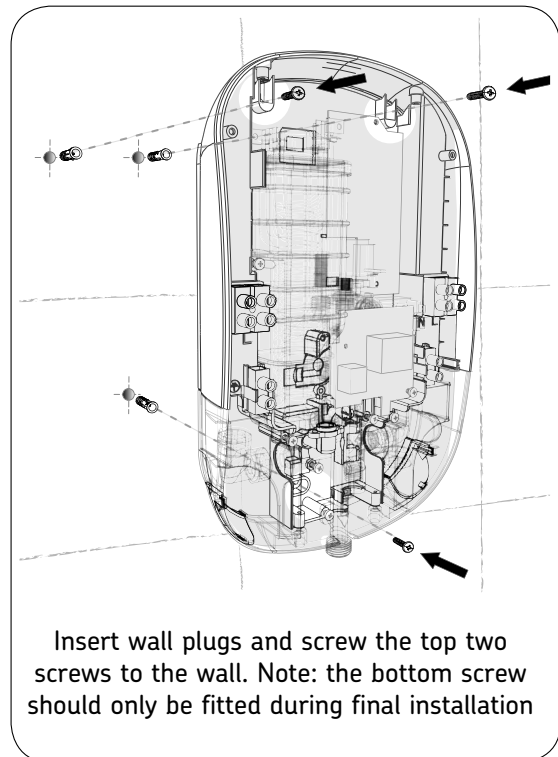
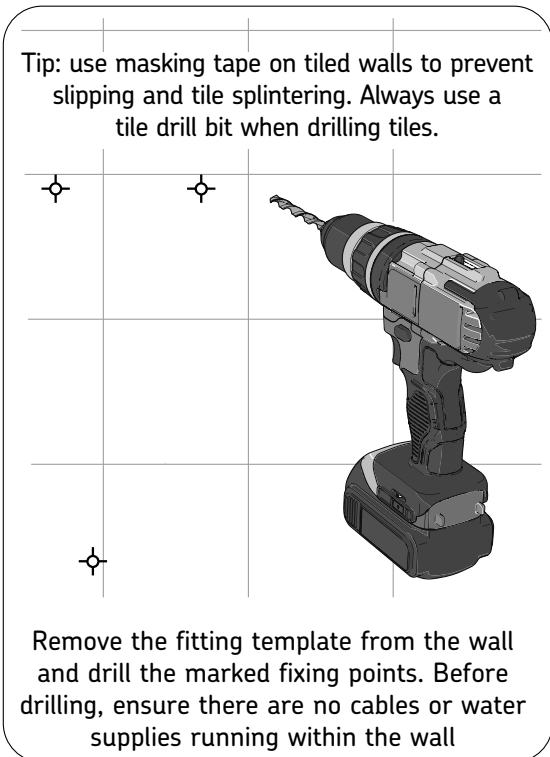

Once the cable and pipe connections have been made, reassemble the bottom cover plates.

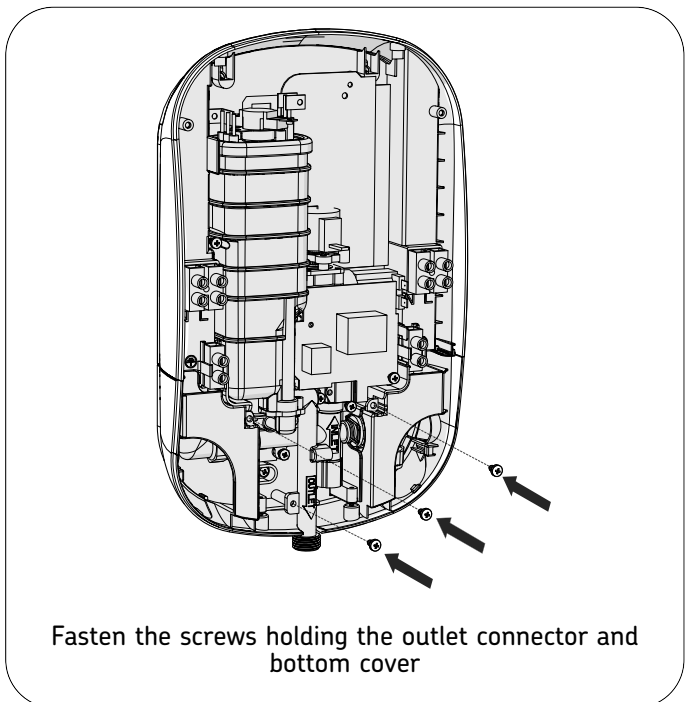
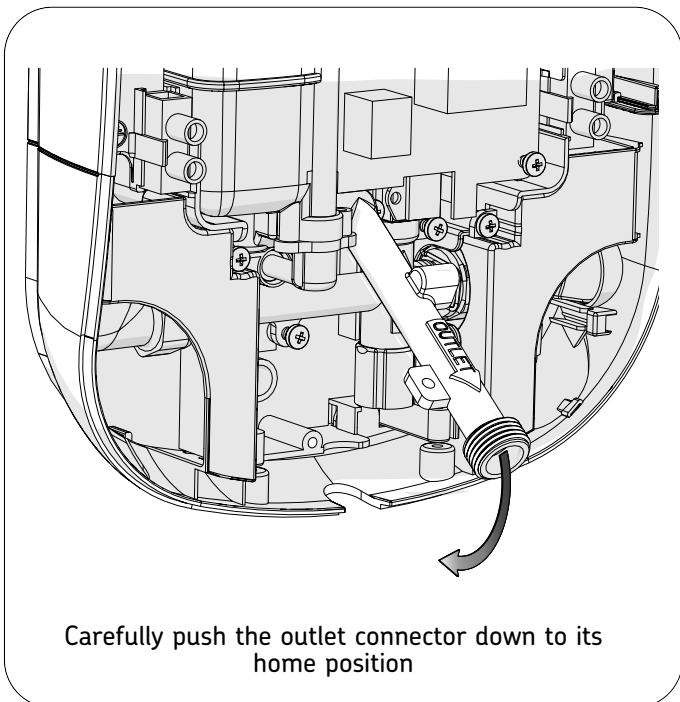
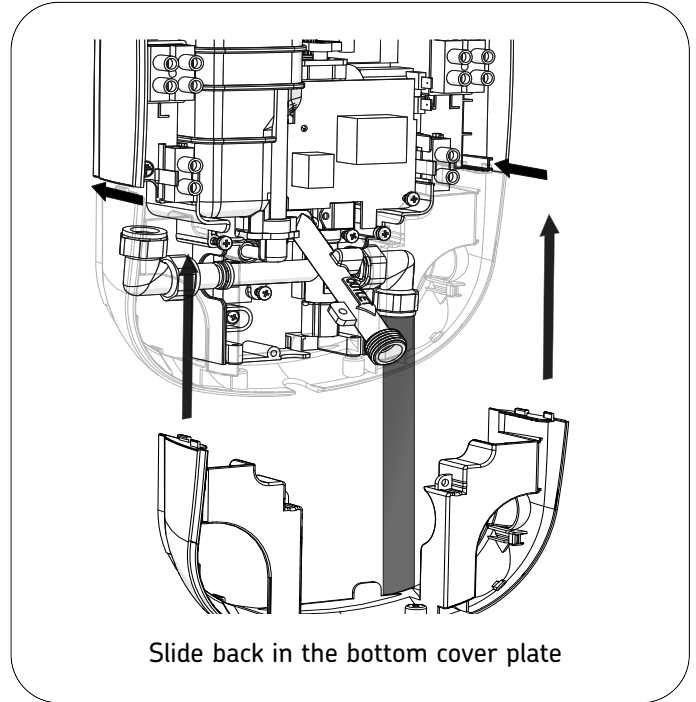
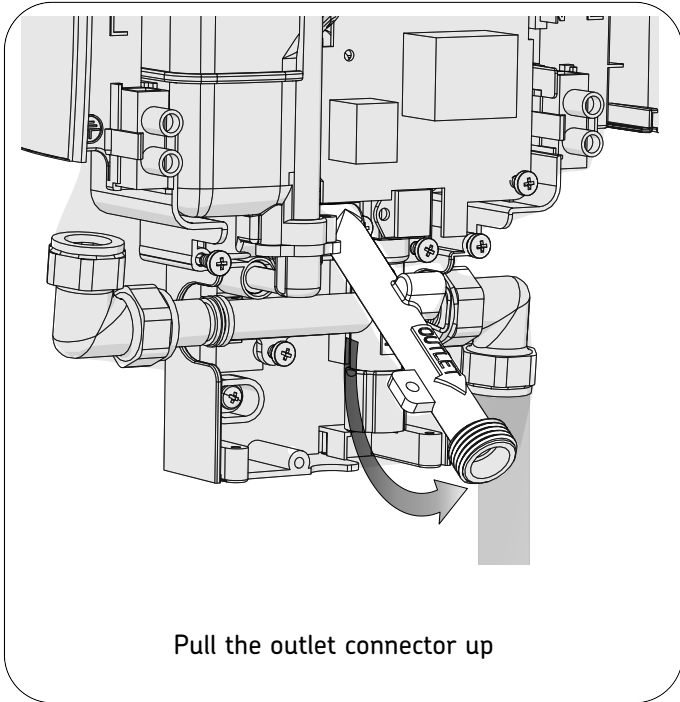

Ensure all connectors are correctly inserted before the cover is refitted.

Refit the Front Cover taking care not to trap the ribbon cable or any other wires.

Only use the supplied screws to secure the front cover. Failure to do so, can cause internal damage to the appliance.

Do not seal the shower to the wall with silicone sealant.

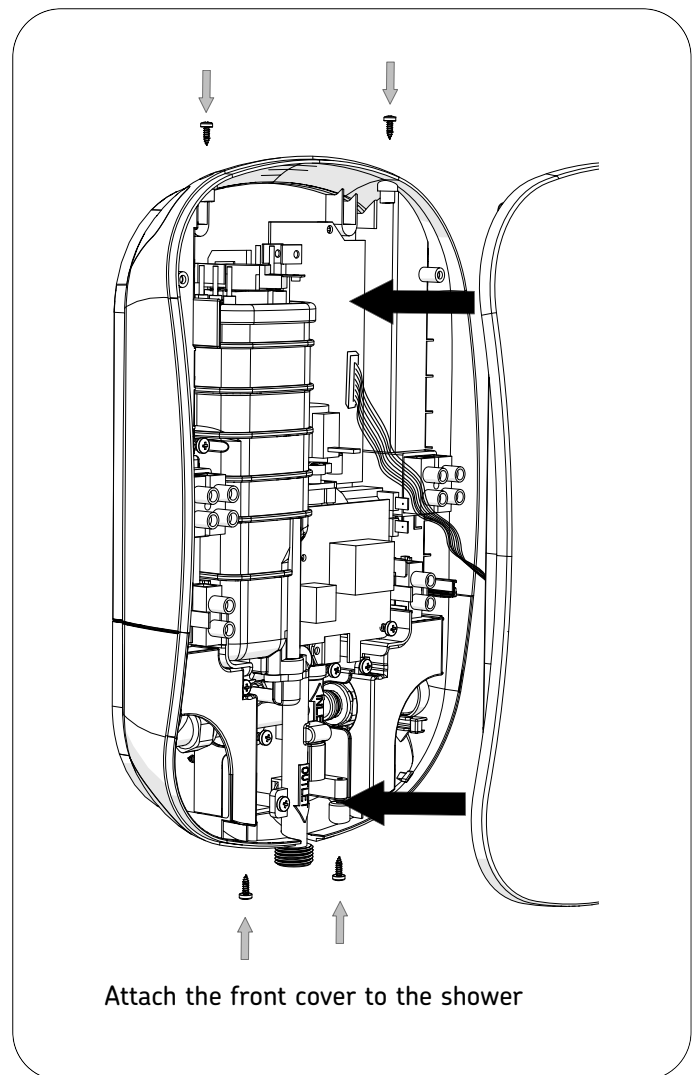
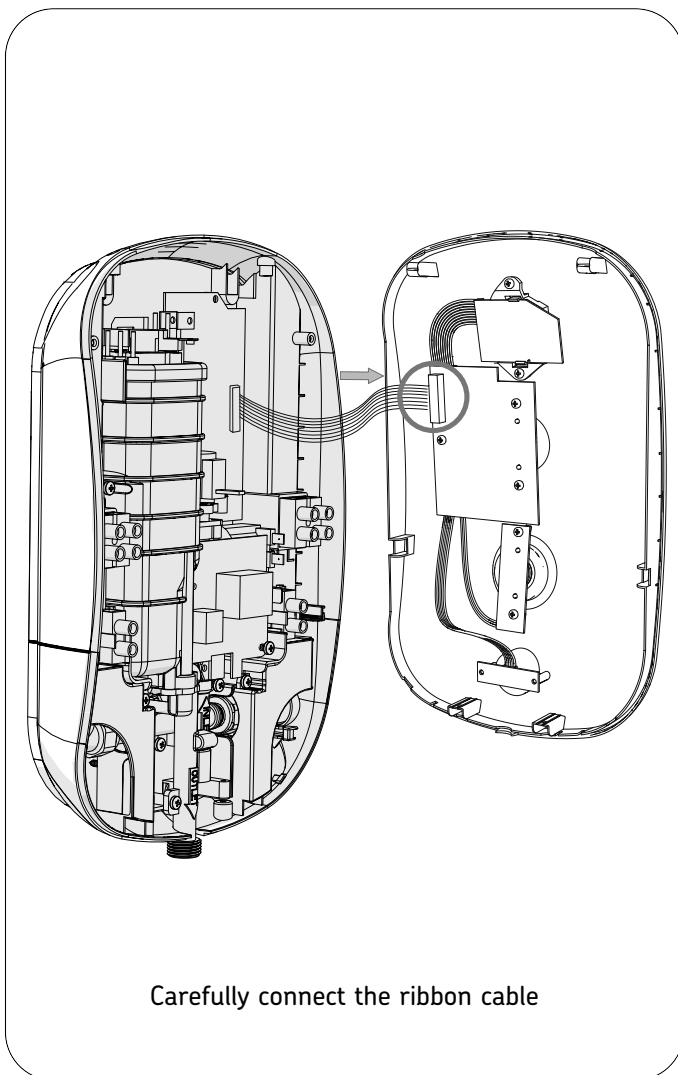

COLD WATER FEED ONLY - Never fit the appliance to the hot water supply.

The shower hose retainer (supplied in the accessory pack) should be used. The installation should comply with Water Regulations and prevent water supply contamination.

To ensure activation of the heating elements, the shower must be connected to a mains cold water supply with a minimum running pressure of 50kPa (0.5 bar) recommended 1 bar with a maximum static pressure of 1000kPa (10 bar).

Note: For optimal product performance the recommended minimum dynamic water pressure should be 100kPa (1 Bar). Dynamic pressure should not fall below 50kPa (0.5 bar) for example when other draw off's are used, such as flushing the toilet as this may cause the shower temperature to fluctuate.

Note: The manufacturer's rigorous quality systems may require operating the shower with water at the factory. Any water will be removed where possible, however there may be a small amount of water residue left in the shower.

There are 8 water inlet points for easy installation and servicing.

The plumbing installation must comply with the local Water Authorities and should be in accordance with the latest Building Regulations.

Plumbing work must be completed before any electrical connections are made.

Make sure there is a cold water feed near to the installation with a local service isolation valve.

Before assembly, flush the water supply pipes thoroughly to remove debris in the pipework (allow the water to run with the main stopcock open for about 3 mins), to prevent debris and dirt particles from blocking the filter which might affect the function of the shower.

DO NOT solder pipes or fittings within 110mm of the shower appliance.

DO NOT fit any form of outlet flow control to the water heater.

DO NOT use excessive force when making connections to the water supply inlet, the flexible hose or the spray head.

Note: An isolating stop valve must be provided on the cold water feed before connecting to the shower. The isolation valve (not supplied) should be fitted as close as is practicable to the water supply inlet of the shower heater whilst being accessible for maintenance and servicing purposes.

Determine pipework position and select the inlet option most suited to your situation. Always prime pipework and flush clear of debris. To prevent a dead leg occurring in the inlet pipework install the inlet plug into the unused inlet pipe, see separate instruction sheet.

Side Entry

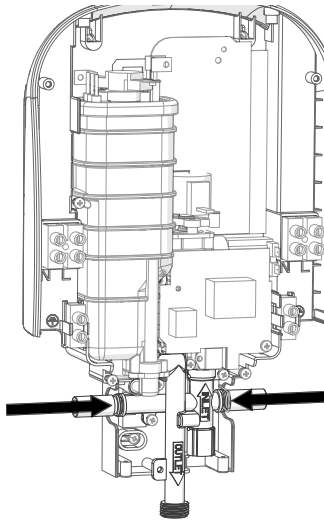

Left or right side inlet. You may need to remove thin areas of plastic cover to facilitate pipe entry.

Rear Entry

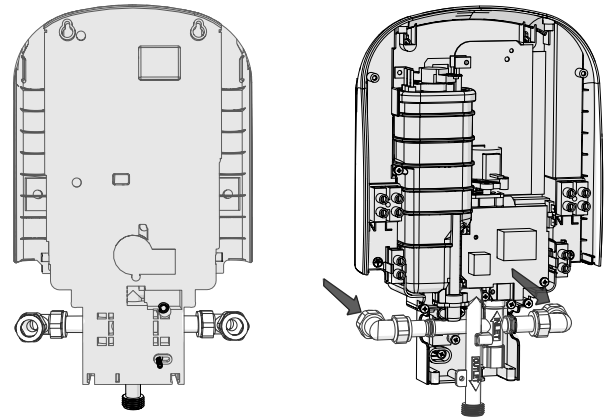

Left or right side rear inlet.

Bottom Entry

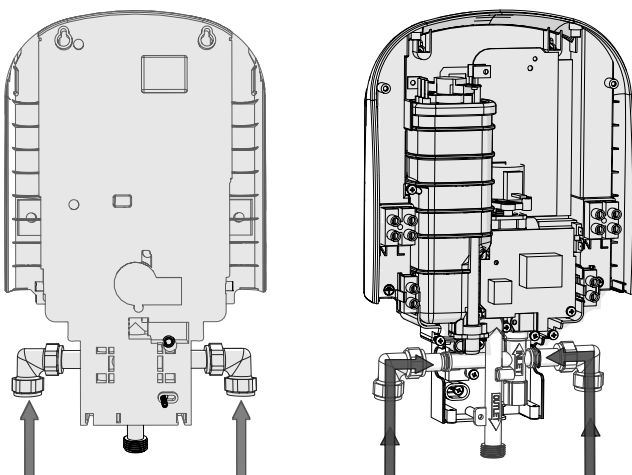

Left or right side bottom inlet.

Top Entry

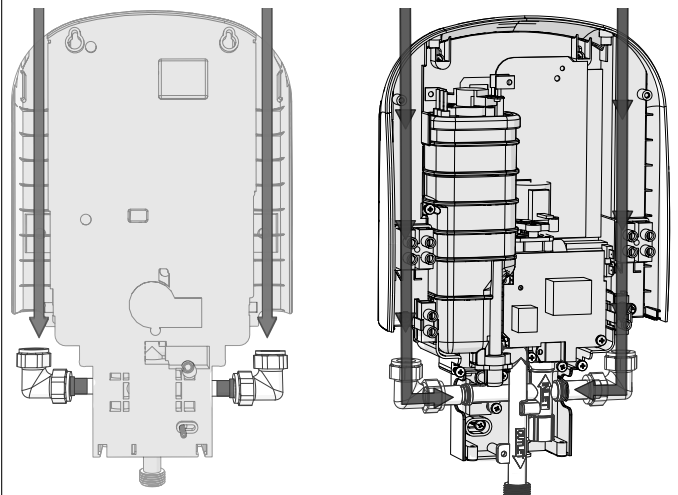

Left or right side top inlet.

Note: Some water from the factory testing may escape when the bottom blanking plug is removed.

CONNECT PIPEWORK AND SECURE THE APPLIANCE TO THE WALL

Separately flush the pipework to remove any debris before connecting to the shower

Note: For ease of installation and servicing, rear entry pipe is only recommended if the top, side or bottom entries are not possible. This pipework must not apply strain to the elbow fitting on the shower. Failure to observe this essential precaution will invalidate the warranty.

Securely fix the shower appliance to the wall and make sure it is vertical.

Do not connect the shower handset yet. Only connect the hose to the shower outlet without the handset at this time and point the hose into the bath, shower tray or wet floor.

Plumbing Check List

- ✓ Check that finished walls are sound and free from cracks or loose tiles or grout. Make sure that the appliance and all surfaces are clean, dry and free from loose debris or dust.
- ✓ The unit must be mounted onto the finished wall or tiled surface (on top of the tiles). DO NOT tile up to or seal around ANY PART of the unit using silicone sealer after fixing to the wall.
- ✓ Turn on the water supply and check there are no leaks - no water should flow through the shower at this point. The maximum static water pressure is 10 bar - The minimum operating dynamic pressure must be at least 0.5 bar. Recommend that for optimum performance this is 1 bar minimum.
- ✓ Place absorbent material around the inlet areas in case of leaks.
- ✓ Checked that there are no leaks
- ✓ Turn off the supply, dry off any water in and around the appliance before connecting or reinstating the electricity.



Caution - Danger of Death 230V AC
Lethal Voltage present on the AC supply.

WARNING - THIS APPLIANCE MUST BE EARTHED

The installation, supply cable and circuit protection must conform to the current wiring regulations and be sufficient for the amperage required and length of cable run. Before making electrical connections within the installation, ensure that the electrical supply has been isolated.

The shower must be connected to its own independent electrical circuit.

DO NOT connect any other device to the power source.

Check your consumer unit (main fuse box) has a main switch rating of 80A or above and that it has a spare fuse way which will take the miniature circuit breaker (MCB) necessary for the shower (see schematic of installation circuit). If your consumer unit has a rating below 80A or if there is no spare fuse way, then the installation may require a new consumer unit serving the property or just the shower. Contact the local electricity company if in any doubt.

The current carrying capacity of the cable must be at least that of the shower circuit protection. Refer to the current wiring regulations to determine minimum cable size. A maximum of 10mm² can be fitted to the shower. Site conditions must be assessed by a competent electrician to determine correct cable size and permissible circuit length.

Shower circuit cable separation from other circuits must meet wiring regulations.

This appliance is only intended to be permanently connected to the main power supply via an independent double-pole isolation switch. Other electrical equipment must not be connected to the same shower circuit. A 30mA residual current device (RCD) MUST be installed. This may be part of the consumer unit or a separate RCD unit.

This appliance must be earthed.

All components must be rated and installed in accordance with wiring regulations. This appliance must be earthed.

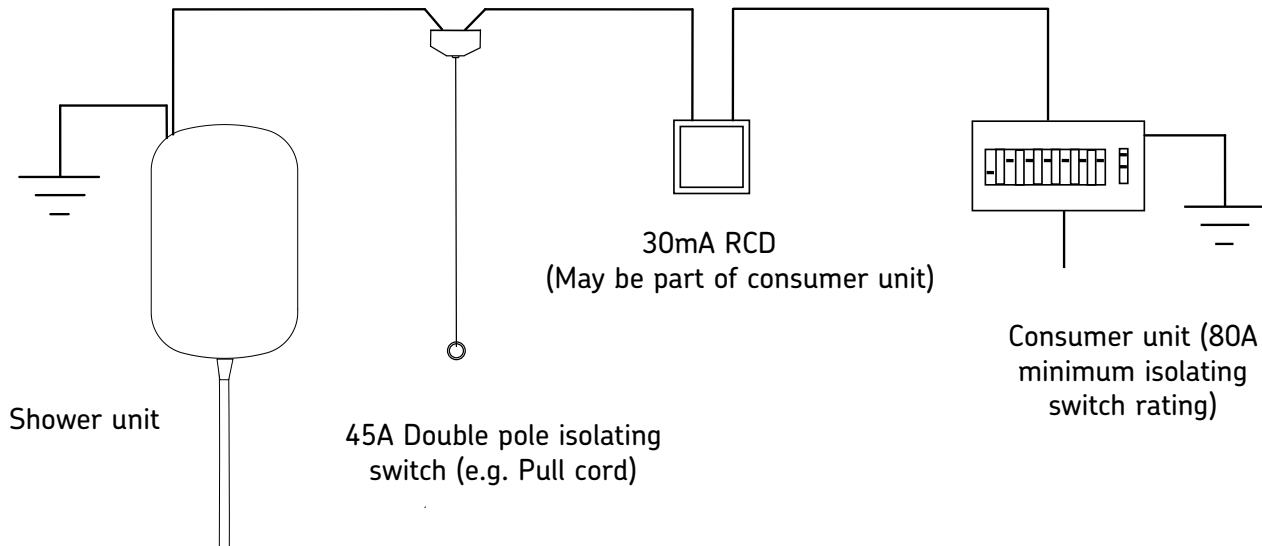

For adequate circuit protection DO NOT use a rewire-able fuse. Instead use a suitably rated miniature circuit breaker or cartridge fuse.

A 30mA residual current device (RCD) must be installed.

A 45 amp double pole isolating switch with a minimum contact gap of 3mm in both poles must be incorporated in the circuit.

The isolating switch must have a mechanical indicator showing when the switch is in the OFF position, and the wiring must be directly connected to the switch.

The isolating switch must be accessible and clearly identifiable, although out of reach of a person using a fixed bath or shower. The cord of a cord-operated switch should be placed so that it is not possible to touch the switch body whilst standing in a bath or shower cubicle.

Where shower cubicles are located outside of a bathroom, all socket outlets in the room must be protected by a 30mA RCD. Consult the wiring regulations.

It is recommended to use the shortest cable route possible from the consumer unit to the shower.

Determine cable entry position

Important: Only connect to Left OR Right terminal blocks. Under no circumstances make connection to Left AND Right terminal blocks

Side Entry

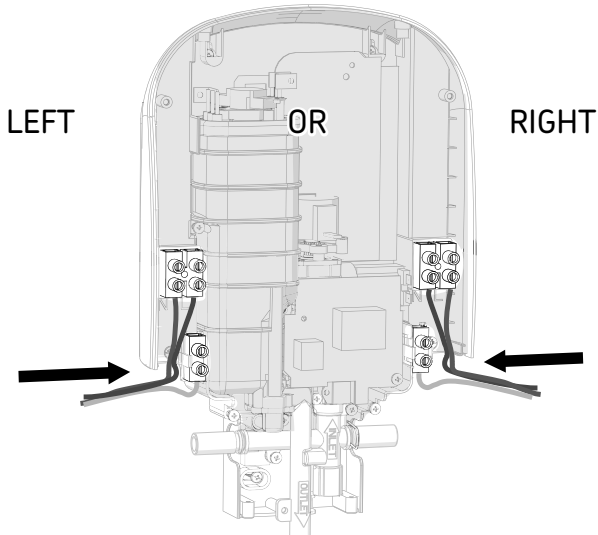

Left or right side cable entry, you may need to remove thin areas of plastic cover to facilitate cable entry.

Rear Entry

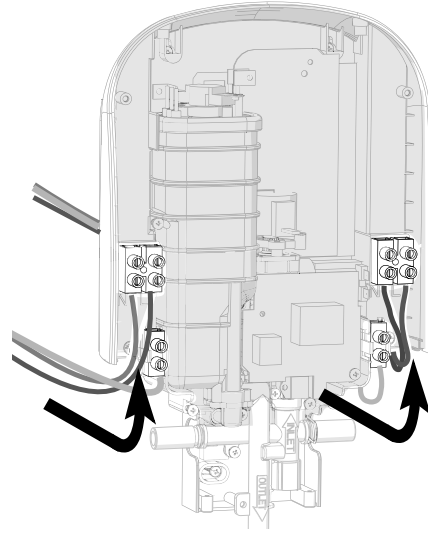

Left or right side rear cable entry.

Bottom Entry

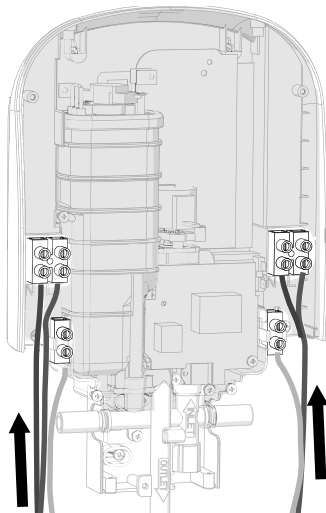

Left or right side bottom cable entry.

Top Entry

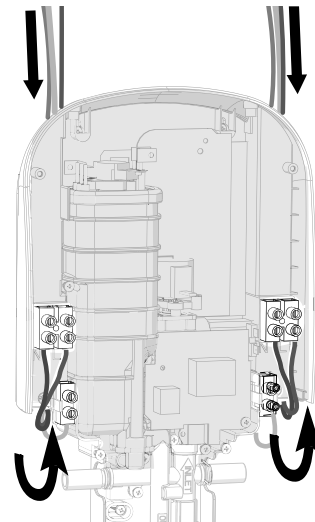

Left or right side top cable entry.

Trim and replace pipe and cable entry covers.

Note: Depending on cable size and entry point used, it may be necessary to strip back the outer cable sheath sufficiently to allow cables to be directed to the terminal connection block within the unit.

Wireless Waste Pump Connections

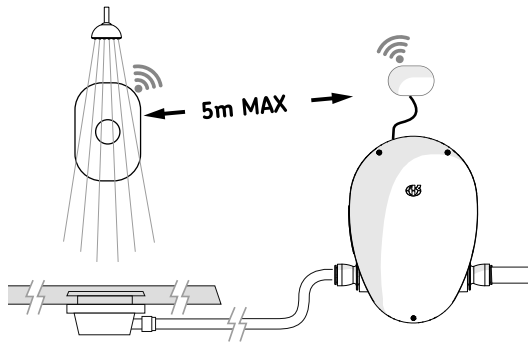

If you wish to connect the pump to the shower wirelessly, an optional wireless pump module is required. Please enquire using stock code: 29089 as a reference and follow the separate wireless pump interface instructions. Select the wireless pump DIP switch setting (Page 27).

Wired Waste Pump Connections

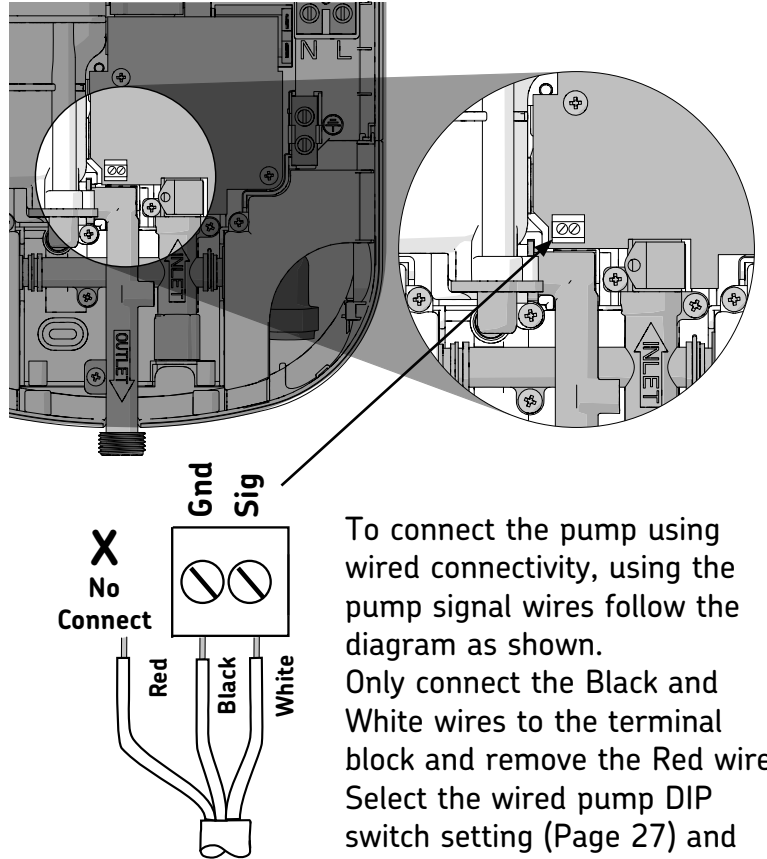

To connect the pump using wired connectivity, using the pump signal wires follow the diagram as shown. Only connect the Black and White wires to the terminal block and remove the Red wire. Select the wired pump DIP switch setting (Page 27) and wired pump setting (Page 26).

Hold the Power Button on for 6+ seconds for wired pump selection

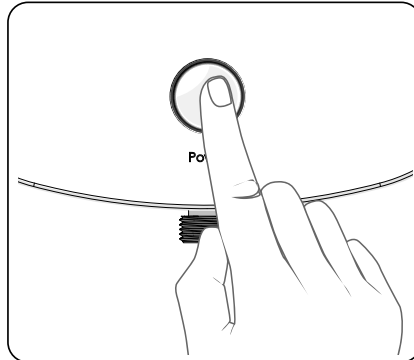

Select between Pulsed Mode (proportional) or Switched Mode (on/off)

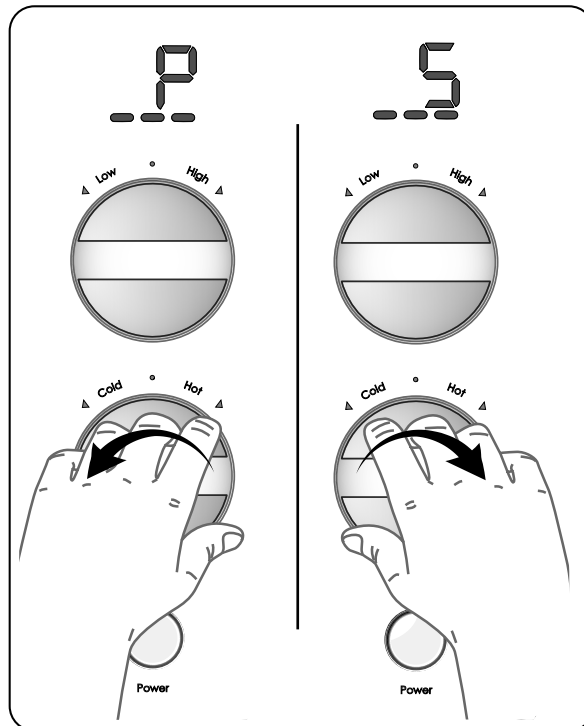

Press the Power button to confirm signal selection.

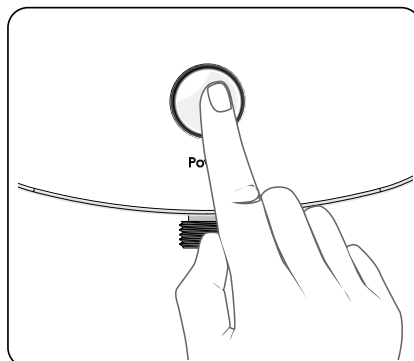

Factory Settings

STD		COLD FLUSH
TEMP. 47°C		TEMP. 43°C
		TEMP. 41°C
SOUND ON		SOUND OFF
B/T OFF		B/T ON
WIRED PUMP		WIRELESS PUMP

The shower is set in its factory setting when delivered.

Pump Setting

	Wired Setting	Wireless Setting	
STD			COLD FLUSH
TEMP. 47°C			TEMP. 43°C
			TEMP. 41°C
SOUND ON			SOUND OFF
B/T OFF			B/T ON
WIRED PUMP			WIRELESS PUMP

Refer to Pump and Wireless Pump Interface Installation instructions for further detail.

Temperature Settings

The shower maximum water temperature can be set to either 41°C, 43°C (Factory Setting) or 47°C by setting the DIP switches located on the control PCB inside the front cover.

MAX. TEMP. 41°C		MAX. TEMP. 43°C		MAX. TEMP. 47°C		
STD		COLD FLUSH		STD		COLD FLUSH
TEMP. 47°C		TEMP. 43°C		TEMP. 47°C		TEMP. 43°C
		TEMP. 41°C				TEMP. 41°C
SOUND ON		SOUND OFF		SOUND ON		SOUND OFF
B/T OFF		B/T ON		B/T OFF		B/T ON
WIRED PUMP		WIRELESS PUMP		WIRED PUMP		WIRELESS PUMP

Mode Settings

STD Mode		COLD FLUSH Mode		SOUND Mode		
STD		COLD FLUSH		STD		COLD FLUSH
TEMP. 47°C		TEMP. 43°C		TEMP. 47°C		TEMP. 43°C
		TEMP. 41°C				TEMP. 41°C
SOUND ON		SOUND OFF		SOUND ON		SOUND OFF
B/T OFF		B/T ON		B/T OFF		B/T ON
WIRED PUMP		WIRELESS PUMP		WIRED PUMP		WIRELESS PUMP

The shower will start at the temperature and flow settings last used when the shower was turned off.

When the shower is switched on in this mode, no heating will occur and only cold water will flush into the system. This will prime the heater tank.

The sound can be turned on or off using this switch.

Cold Water Flushing & Priming

Before operating the shower, it must be primed with cold water using the cold flush setting

Turn on power at pull cord/switch.

Put into cold water flush mode. To do this, refer to the dip switch mode settings on page 27. Once the shower is flushed and primed, reset the dip switch back to STD position.

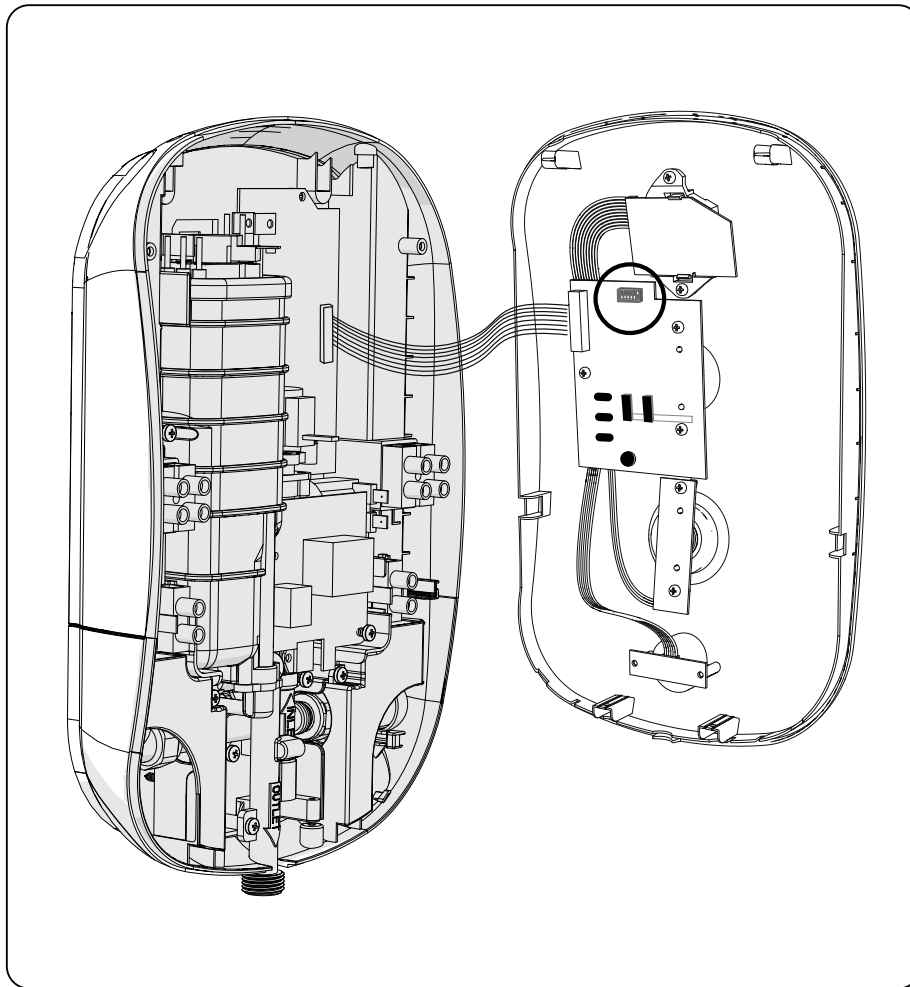

The Dip switch is located on the inside of the cover

Checking the Power Button

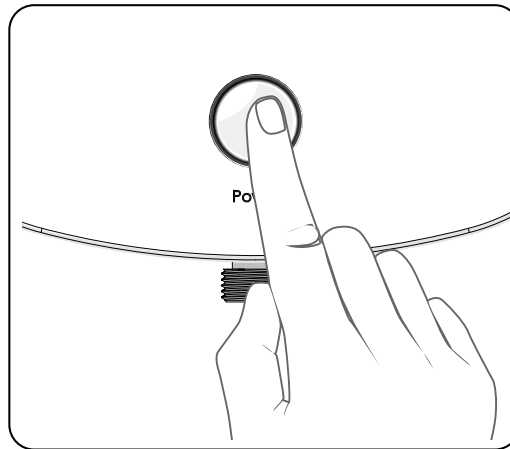

Press and release the power button

Checking the Temperature Control

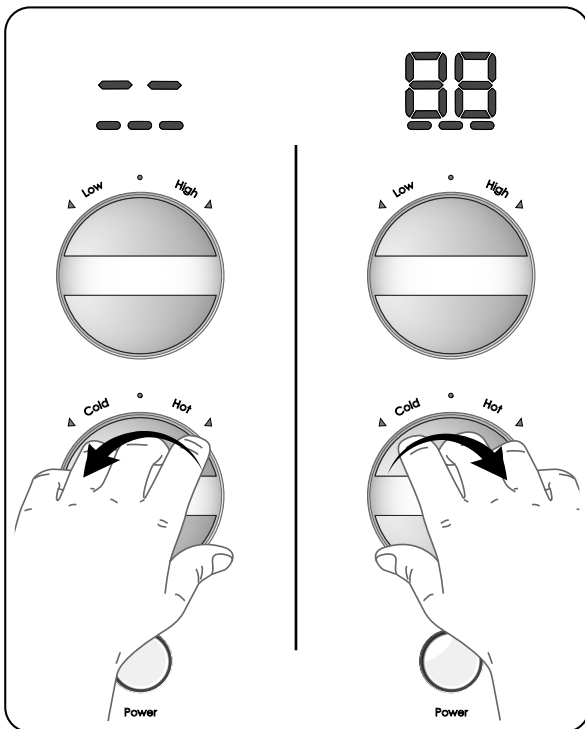

Checking the Flow Control

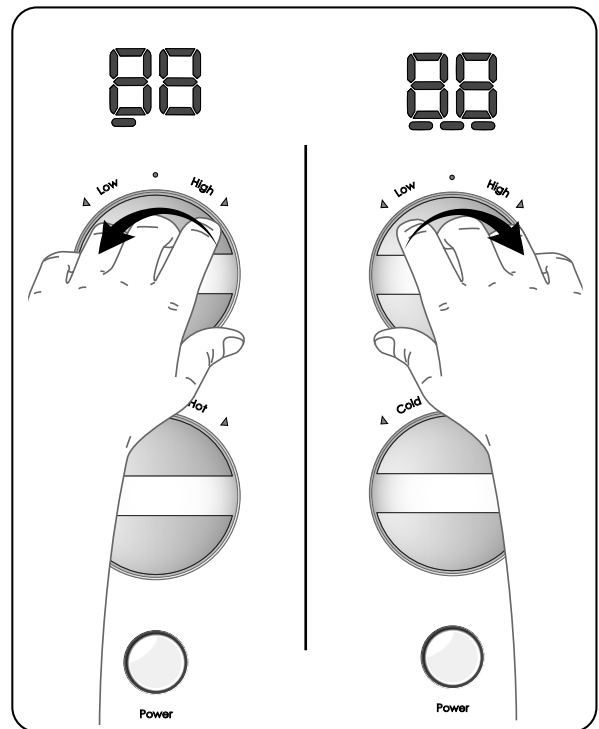

Confirm the operation of the Temperature and Flow increase and decrease knobs, whilst ensuring all lights are functioning

Press the Power button to revert to standby mode

It is important to complete the installation and record the commissioning tests to provide a performance reference point for future tests.

In the event that the shower fails to respond to any push-button instruction or exhibits unusual performance characteristics during operation, turn off the electrical supply by operating the pull-cord switch or isolating switch. Wait for a few seconds for the shower to reset, then turn the power back on and push the on/off button. If the problem still persists, note which fault LED is lit/flashing, then refer to the Fault Finding section.

This Shower is fully thermostatic and will automatically compensate for any seasonal changes to the inlet temperature and flow rates as long as they remain within the specified conditions see shower specification page 12.

Fault Display

LP

LP : Low Flow/Pressure

The shower contains a 'LOW PRESSURE' indicator which will operate, if the following conditions occur:

- Low water pressure (below 0.5 bar maintained). For optimum performance, a minimum constant 1 bar is recommended
- Blocked or partially blocked spray plate
- Blocked inlet filter
- Water supply flow rate is below 2 litres per minute

If any of the above low pressure conditions occur, the unit will STOP as this will cause the shower to be over temperature and the over temp LEDs will flash. Turn off the electrical supply by operating the pull-cord switch or isolating switch, then turn the power back on and instead of waiting for the shower heater element/tank to cool down, perform a COLD FLUSH see page 28. If the problem still persists then refer to Fault Finding. Ensure all plumbing connections are watertight. Check the hose and shower handset. If the filter is suspected to be blocked, clean it. If the problem still persists, contact AKW Technical Enquiries.

E0

E0 : Wireless Pump Failure

Refer to separate wireless pump interface instructions - Troubleshooting guide

E1

E1 : Inlet Thermistor Fault

Requires internal repair/reset

E2

E2 : Outlet Thermistor Fault

Requires internal repair/reset

E3

E3 : Uncontrolled over Temperature

If the water temperature rise is uncontrolled the shower will turn off to prevent an unsafe temperature and E3 LED will flash immediately. The shower will not turn back on until the water inside the unit has cooled to a safe level. Perform a COLD FLUSH to cool the heating elements quicker, see page 28. If the fault persists, then a reset or internal repair may be required.

Overheating

This Shower is fully thermostatic and will automatically compensate for any seasonal changes to the inlet temperature and flow rates as long as they remain within the specified conditions see shower specification page 12.

The shower is fitted with an over-temperature indicator and a safety cut-out device. In the event of abnormal operation which could cause unsafe temperatures within the unit, the device will disconnect the heating elements and switch off the shower. The flow and the over temp LED will then flash.

If the water temperature rises above the desired maximum temperature setting momentarily then ***No. 10 temperature LED will flash at a (2Hz rate). The shower will control the water temperature back to the desired level.

If the water temperature rise is uncontrolled the shower will turn off to prevent an unsafe temperature and the **Temperature LEDs 1 to 10 will flash immediately. The shower will not turn back on until the water inside the unit has cooled to a safe level. Perform a COLD FLUSH to cool the heating elements quicker, see page 28. If the fault persists the a reset or internal repair may be required. Ensure all electrical connections are tight to prevent overheat.

Low Flow/Pressure Failure

The shower contains a 'LOW FLOW/LOW PRESSURE' indicator which will operate, if the following conditions occur:

- Low water pressure (below 0.5 bar maintained) for optimum performance a minimum constant 1 bar is recommended
- Blocked or partially blocked spray plate
- Blocked inlet filter
- Supply flow rate is below 2 litres per minute

If any of the above low pressure conditions occur, the unit will STOP as this will cause the shower to be over temperature and the over temp LEDs will flash. Turn off the electrical supply by operating the pull-cord switch or isolating switch, then turn the power back on and instead of waiting for the shower heater element/tank to cool down, perform a COLD FLUSH see page 28.

If the problem still persists then refer to Fault Finding. Ensure all plumbing connections are watertight. Check the hose and shower handset. If the filter is suspected to be blocked, clean it. If the problem still persists, contact AKW Technical Enquiries.

This should only be done if you suspect reduced flow rate or water hardness build up.

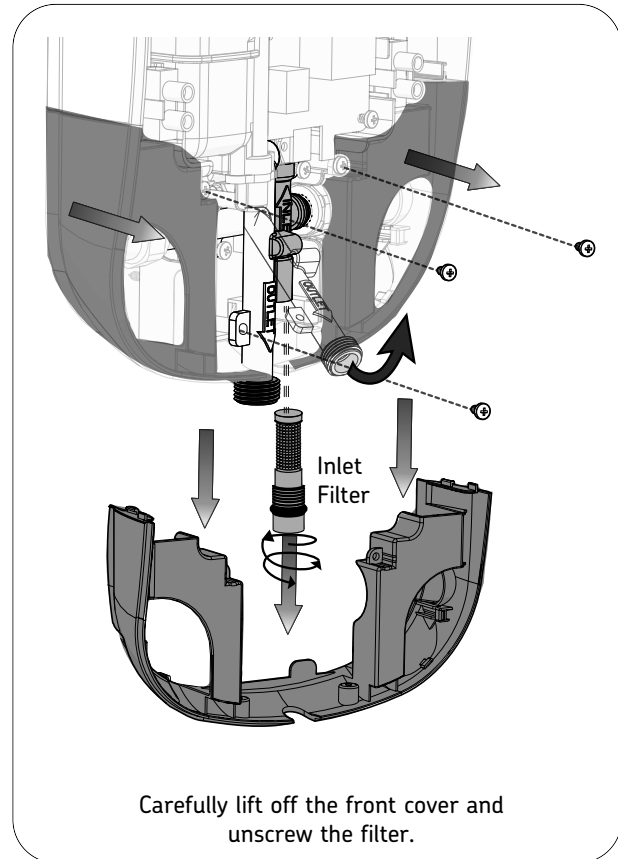
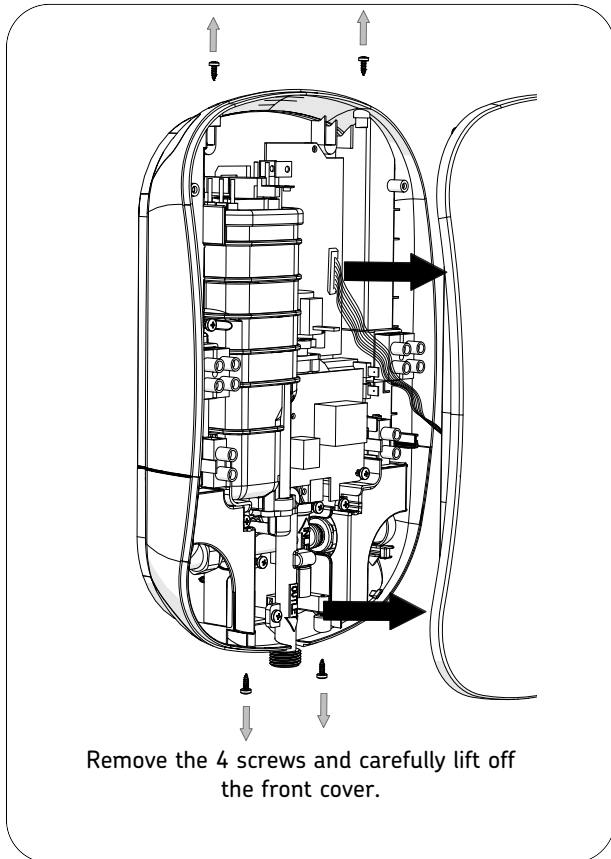

Follow the disassembly instructions on page 14 to expose the inlet filter. Always isolate the electricity supply before opening the cover.

Ensure that the electrical supply is switched off at the mains.

Ensure that the water supply is turned off.

Rinse the filter in water and once this is clean then return to the inlet housing and reassemble.

Note:

All installation, commissioning and in-service testing must be undertaken by a suitably qualified engineer.

COMMISSIONING TESTS

Record the following information to provide a performance reference point for future in-service tests.

Shower Serial Number (SN) _____

Date of Commissioning ____ / ____ / ____

Max temperature setting is set to _____ °C

Mains Water supply Running Pressure _____ Bar

Water supply temperature _____ °C

Mains terminal Voltage _____ Vac

With shower turned on at Max flow and Max temperature setting,
record the water temperature when it is stabilised _____ °C

Record details of test equipment (brand, model, serial number and calibration information) used to provide the above information, if necessary record on separate paper and attach to this instruction booklet.

-Blank Page-

-Blank Page-

Orderline
01905 823299

General Enquiries
01905 823298

Technical Enquiries
01905 560219
tech@akw-ltd.co.uk

Fax
01905 823297

Website
www.akw-ltd.co.uk

Quotes & Orders Email
orders@akw-ltd.co.uk

Sales & Enquiries Email
sales@akw-ltd.co.uk

AKW, Pointon Way,
Hampton Lovett,
Droitwich Spa,
WR9 0LR



Social



facebook.com/akwone



twitter.com/akw_one



youtube.com/akwstyleability



linkedin.com/company/akw

As part of our continuous improvement programme we appreciate any feedback on our products and instructions. If you have any tips or comments please let us know!